

AD-50i

50-lb Capacity OPL Dryer

Standard Features:

- Variable drum speed
- Pre-heat system
- Trans-axial airflow
- Fully insulated cabinet
- Double-pane door glass
- Self-cleaning lint screen
- Direct spark ignition
- Two-point roller support
- "IMC®" intuitive micro control with auto-dry system
- S.A.F.E. (Sensor Activated Fire Extinguishing System)
- Single-phase reversing basket
- Stainless steel basket and fronts
- Simplified inverter drive system
- Fits through standard 36" door
- Available in gas, steam & electric

OPL



AD-50i OPL Dryer

Optional Features:

- Automatic Airflow Compensator (AAFC)
Optional AAFC adjusts exhaust fan speed to improve exhaust flow with increased back pressure caused by installation issues. This exclusive patented technology adjusts fan speed and enhances dryer performance. Measurements are calculated in real-time, on an ongoing basis to optimize dry-times and efficiency.

Why Purchase AD-50i?

Performance

The achievement: Through innovative design, the i-Series dryers achieve higher performance, industry-leading efficiency, shorter dry times and safer, more reliable operation. What an owner wants, an owner gets: saving money on utilities, payroll, and maintenance. Anyone can say their dryers have the best performance. The Intelligent Dryer Series has the features to prove it.

Reliability

Demanding owners require more than just outstanding performance for their toughest laundry environments. To accommodate owners, we designed the i-Series with years of reliable operation as an absolute design necessity. A sturdy steel-welded cabinet, fewer moving parts and top-quality components are the foundation of the line. Costly repairs and unwanted downtime are now a thing of the past.

IMC— Intuitive Micro Controls is easy-to-use and 100% customizable.

The IMC is an intelligent and simple-to-use control system that provides one-touch program selection. By creating a fully integrated drying system, ADC utilizes IMC to control all aspects of the drying process to minimize user error and maximize drying speed and efficiency.

Your local ADC independent authorized distributor



www.adclaundry.com

AD-50i

AD-50i Specifications

Maximum Capacity (dry weight)	50 lb	22.67 kg
Tumbler Diameter	32-3/4"	83.18 cm
Tumbler Depth	37-1/2"	95.25 cm
Tumbler Volume	18.3 cu ft	518.19 L
Tumbler/Drive Motor	1 hp	0.75 kW
Blower/Fan Motor*	3/4 hp	0.56 kW
Cabinet Width	34-1/2"	87.63 cm
Cabinet Depth	49-3/8"	125.41 cm
Cabinet Height	73-5/8"	187.1 cm
Door Opening (diameter)	27"	68.58 cm
Door Sill Height	29-1/8"	74 cm
Water Connection	3/4"-11.5 NH (North America) 3/4" B.S.P.T. (Outside North America)	
Dryers per 20'/40' Container	10 / 20	
Dryers per 48'/53' Container	25 / 28	
Gas	Voltage Available	120-480V 1,3ø 2,3 50/60 Hz
	Approximate Net Weight	655 lb 297.10 kg
	Approximate Shipping Weight	710 lb 322.05 kg
	Airflow	50 Hz 810 cfm 22.93 cmm 60 Hz 850 cfm 24.06 cmm
	Heat Input	125,000 Btu/hr 31,500 kcal/hr
	Exhaust Connection (diameter)	8" 20.32 cm
Inlet Pipe Connection	1/2" N.P.T. (Male) 1/2" B.S.P.T. (Female) (CE and Australia Only)	
Electric	Voltage Available	208-480V 1,3ø 2,3,4w 50/60 Hz
	Approximate Net Weight	660 lb 299.37 kg
	Approximate Shipping Weight	715 lb 324.31 kg
	Airflow	50 Hz 714 cfm 20.21 cmm 60 Hz 746 cfm 21.12 cmm
	Exhaust Connection (diameter)	8" 20.32 cm
	Oven Size	kW BTU Kcal 18.5 63124 15907 20.4 69607 17540 22 75067 18916
Steam	Voltage Available	120-480V 1,3ø 2,3 50/60 Hz
	Approximate Net Weight	685 lb 310.71 kg
	Approximate Shipping Weight	745 lb 337.92 kg
	Airflow	50 Hz 767 cfm 21.71 cmm 60 Hz 920 cfm 26.05 cmm
	Steam Consumption (Max)	105 lb/hr 47.62 kg/hr
	Operating Steam Pressure	150 psi max 10.34 bar
Exhaust Connection (Diameter)	8" 20.32 cm	
Boiler Horsepower (Normal Load)	2.7 Bhp	
Supply Connection	(1) 3/4" N.P.T. (Male)	
Return Connection	(1) 3/4" N.P.T. (Male)	

3/29/15

* Blower/fan motor for single-phase steam is 1 hp (0.75 kW). Blower/fan motor for 3-phase, all heat, is 1 hp (0.75 kW).

* If configuration ordered is 1ph motor, 3ph heat dryer will be 4w.

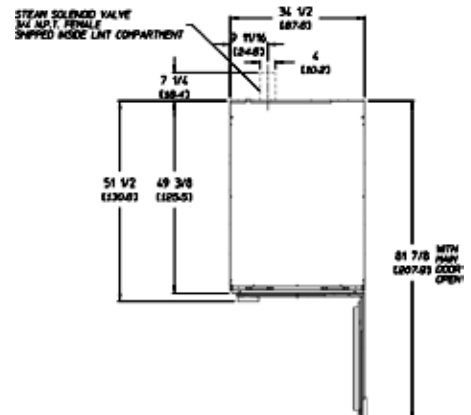
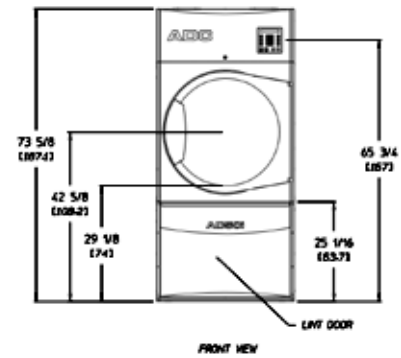
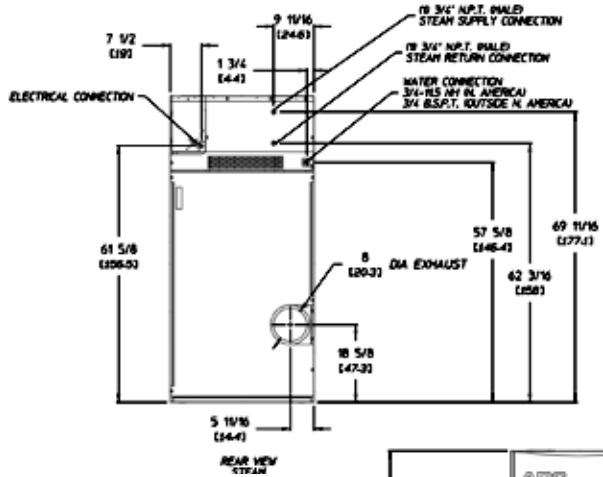
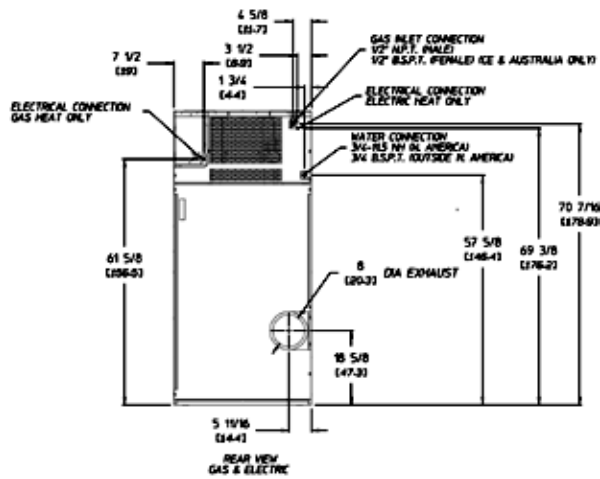

QY160040 1/17

Electrical Service Specifications					
GAS & STEAM HEAT					
SERVICE VOLTAGE	PHASE	WIRE SERVICE	APPROX AMP DRAW		CIRCUIT BREAKER
			60 Hz	50 Hz	
120	1ø	2	9.8	--	15
208	1ø	2	8	--	15
220	1ø	2	5	5	15
230	1ø	2	5	5	15
240	1ø	2	5	5	15
208	3ø	3	4.45	--	15
220	3ø	3	8.35	4.45	15
230	3ø	3	8.35	4.45	15
240	3ø	3	8.35	4.45	15
380	3ø	3	--	2.73	15
400	3ø	3	--	2.73	15
416	3ø	3	--	2.73	15
440	3ø	3	4.53	--	15
460	3ø	3	4.53	--	15
480	3ø	3	4.53	--	15

Electrical Service Specifications						
ELECTRIC HEAT						
SERVICE VOLTAGE	PHASE	WIRE SERVICE	kW	APPROX AMP DRAW		CIRCUIT BREAKER
				60 Hz	50 Hz	
SINGLE-PHASE HEAT SINGLE-PHASE MOTOR						
220	1ø	2	18.5	94.0	89.0	125
230	1ø	2	20.4	98.6	93.6	125
240	1ø	2	22	101.7	96.6	150
THREE-PHASE HEAT SINGLE-PHASE MOTOR						
220	3ø	3	18.5	55.0	53.4	70
230	3ø	3	20.4	57.7	56.1	80
240	3ø	3	22	59.5	57.8	80
380	3ø	3*	18.5	--	34.7	50
400	3ø	3*	20.4	--	36.1	50
416	3ø	3*	22	--	37.2	50
THREE-PHASE HEAT THREE-PHASE MOTOR						
208	3ø	3	22	70	--	90
220	3ø	3	18.5	57	55	80
230	3ø	3	20.4	60	58	80
240	3ø	3	22	61	59	80
380	3ø	3	18.5	--	33	50
400	3ø	3	20.4	--	34	50
416	3ø	3	22	--	35	50
440	3ø	3	18.5	29	--	40
460	3ø	3	20.4	30	--	40
480	3ø	3	22	31	--	40



88 Currant Road, Fall River, MA 02720-4781 • 508.678.9000