



SPEED QUEEN® MULTI-HOUSING LAUNDRY SOLUTIONS

# Top Load Washer

## Quantum™ Gold

Prep for Card | Coin Drop Installed | Prep for Coin

### Built for Reliable Performance

Speed Queen's two-speed top load washer, defined by its simplicity and its performance, provides everything you need to get the job done – and nothing you don't. Speed Queen's top load washer combines heavy-duty construction with reliable operation proven to stand the test of time. Speed Queen® washers provide maximum energy efficiency and long-lasting performance.

- Touch pad control with sound annunciator
- 27 cycle selections

- Extract speed of 710 RPM spins clothes out drier
- Integrated meter case
- Advanced suspension system
- Easy-to-read digital display
- Cycle programming flexibility
- Multi-level vend pricing
- Individual cycle modifier keys
- Durable stainless steel tub standard
- 3.19 cu. ft. (90.3 liters) wash capacity
- Large capacity meter case standard
- Wash Alert™ capability



### Quantum™ Gold Control

The cutting edge Quantum™ control system from Speed Queen® gives you the freedom to manage laundry your way with the power to achieve unmatched levels of revenue. Quantum™ Gold provides users with additional cycle choices while offering new options to help lower operating costs and incorporates tools and options to increase revenue.



# Top Load Washer

## Quantum™ Gold

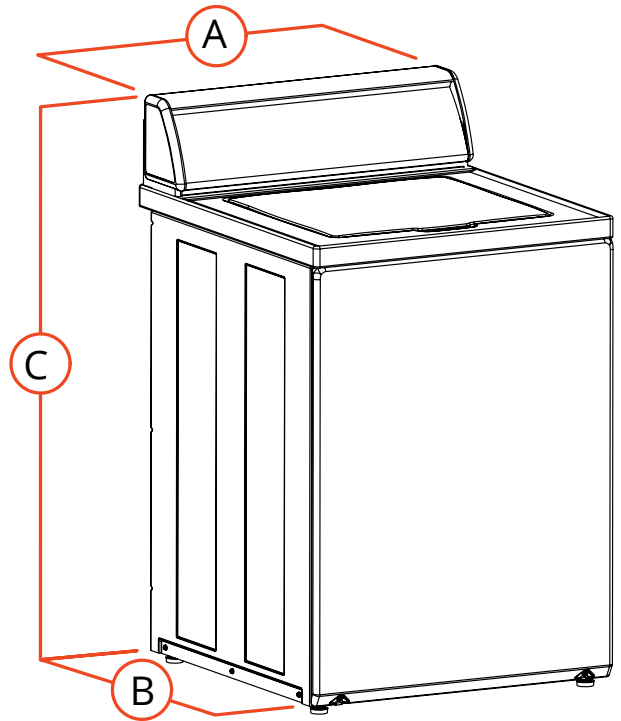
Specifications		
Control Option	Quantum Gold	
Color	White	
Capacity - lb (kg)	16 (7.3)	
Overall Width - in (mm)	25.63 (651)	
Overall Depth - in (mm)	28 (711)	
Overall Height - in (mm)	43 (1092)	
Cylinder Volume - cu. ft. (liters)	3.19 (90.3)	
Spin Speed G-Force (RPM)	150 (710)	
Motor Size - HP (kw)	0.5 (0.37)	
Water Consumption Per Cycle - g (liter)*	28.07 (106)	
IWF (Water Factor) - gal/ft <sup>3</sup> (liters/liter/cycle)*	8.8 (1.18)	
MEF <sub>2</sub> (Modified Energy Factor) ft <sup>3</sup> /kWh/cycle (Liters/kWh/cycle)*	1.35 (38.2)	
Available Water Temperatures	Hot, Warm, Cold	
Available Cycles	Light, Medium, Heavy, Normal, Perm Press, Delicate	
Electrical Requirements (v/Hz/Ph-Amp)	120/60/1 - 15 Amp	
Water Pressure - p.s.i. (bar)	20-120 (1.4/8.3)	
Drain	Pump	
Cylinder Finish	Stainless Steel	
Net Weight - lb (kg)	206 (93.4)	
Shipping Weight - lb (kg)	218 (98.8)	
Shipping Dimensions Approx. - in (mm)	Width	28 (711)
	Depth	30 (762)
	Height	45 (1143)
Agency Approvals	cULus	

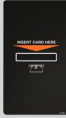

A. Overall Width - in (mm)	25.625 (651)
B. Overall Depth - in (mm)	28 (711)
C. Overall Height - in (mm)	43 (1092)

Models	Activation
SWNNC2SP115TW01	Coin Drop Installed 
SWNNX2SP115TW01	Prep for Coin 
SWNNY2SP115TW01	Prep for Card 

\* Average usage based on multiple load sizes and current DOE test protocol. Real usage will vary depending on load size, composition and cycle selectivity.

For the most accurate information, the installation guide should be used for all design and construction purposes. Due to continuous product improvements, design and specifications subject to change without notice. The quality management systems of Alliance Laundry Systems are registered to ISO 9001.