



SPEED QUEEN® MULTI-HOUSING LAUNDRY SOLUTIONS

Stack Dryer

Quantum™ Gold

Prep for Card | Coin Drop Installed | Prep for Coin

Built for Reliable Performance

Speed Queen's stack dryer offers the same great features as the single load dryer. Two commercial dryers in the space of one, both operating independently, including independent controls for optimum usage. Defined by its simplicity and its performance, Speed Queen provides everything you need to get the job done - and nothing you don't. Speed Queen's stack dryer combines heavy-duty construction with reliable operation proven to stand the test of time. They're designed with less moving parts for one reason: so you'll face fewer maintenance problems and less wear and tear down the road. Speed Queen's dryers provide the perfect balance of heat, airflow and tumble action for optimal performance and efficiency. Bottom dryer is ADA compliant.

- Integrated meter case
- Industry's largest door opening 2.06 sq. ft. (1914 cm²)
- Quiet, efficient blower system
- High efficiency exhaust blower with superior airflow 220 cfm (105 liters/sec)
- 100% serviceable from the front
- Space-saving narrow cabinet 26.875" (683 mm)
- Upfront lint filter easy to clean and secured
- Durable galvanized steel cylinder
- Large capacity meter case standard



Quantum™ Gold Control

The cutting edge Quantum™ control system from Speed Queen® gives you the freedom to manage laundry your way with the power to achieve unmatched levels of revenue. Quantum™ Gold provides users with additional cycle choices while offering new options to help lower operating costs and incorporates tools and options to increase revenue.

Stack Dryer

Quantum™ Gold

Specifications		
Control Option	Quantum Gold	
Color	White	
Capacity - lb (kg)	18 (8.2) ea	
Overall Width - in (mm)	26.875 (683)	
Overall Depth - in (mm)	28 (711)	
Overall Height - in (mm)	78.17 (1986)	
Cylinder Volume - cu. ft. (liters)	7.0 (198) ea	
Motor (Thermal Protected)	0.33 HP	
Type Of Gas (Gas Models Only)	Factory equipped natural	
Air Outlet Diameter - in (mm)	4 (102)	
Exhaust Airflow - cfm (liters/sec)	220 (105)	
Available Cycles	High, Medium, Low, Delicates, No Heat	
Electrical Requirements	Electric	120/240/60/1-30 amp 120/208/60/1-30 amp
	Gas	120/60/1-15 amp
Heating Element	Electric	5350W, 240V 4750W, 208V
	Gas	25,000 Btu
Shipping Dimensions Approx. - in (mm)	Width	33 (838)
	Depth	30 (762)
	Height	80 (2032)
Net Weight - lb (kg)	Electric	270 (122)
	Gas	270 (122)
Shipping Weight - lb (kg)	Electric	280 (127)
	Gas	280 (127)
Agency Approvals	Electric	cULus
	Gas	cCSAus

Models	Voltage/Freq/PH	Activation	
SSENCAGW173TW01	120/240/60/1	Electric	Coin Drop Installed
SSENCAGW153TW01	120/208/60/1		
SSGNAGW113TW01	120/60/1	Gas	
SSENXAGW173TW01	120/240/60/1	Electric	Prep for Coin
SSGNXAGW113TW01	120/60/1		
SSENYAGW173TW01	120/240/60/1	Electric	Prep for Card
SSGNYAGW113TW01	120/60/1		

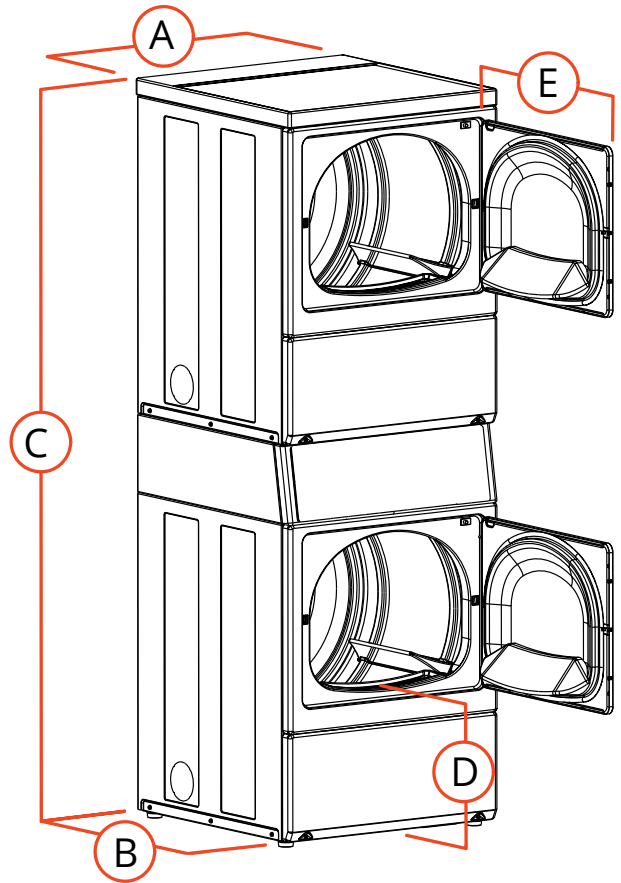

A. Overall Width - in (mm)	26.875 (683)
B. Overall Depth - in (mm)	28 (711)
C. Overall Height - in (mm)	78.17 (1986)
D. Floor To Door Opening - in (mm)	15.44 (392)
E. Door Swing - in (mm)	23.5 (597)

NOTE: Each stack dryer pocket requires its own separate power cord (not supplied).

Electric dryers come equipped for 240/60/1 operation. They can be field converted to operate on 208/60/1 with optional 61928 conversion kit. Gas dryers can be field converted for operation on LP gas with optional 458P3 conversion kit.

For the most accurate information, the installation guide should be used for all design and construction purposes. Due to continuous product improvements, design and specifications subject to change without notice. The quality management systems at Alliance Laundry Systems are registered to ISO 9001.

©2019 Alliance Laundry Systems LLC

Speed Queen by Alliance Laundry Systems

AM20-0011

speedqueencommercial.com